

# KOSRAN

ecv

**OEM CONSTRUCTION MANUFACTURERS**

Profitable Accessory for Price of Deutsch Connector

**KOSRAN - THE VANGUARD OF IMMOBILISATION  
& Telematic Asset Management Technology**

**WE STOP PLANT THEFT & UNAUTHORISED MACHINE USE  
By Employee | Juvenile | Thief**

**CUSTOMERS CONTROL FLEETS | REMOTELY | 24/7  
Reduce Maintenance | Improve Utilisation**



**ELECTRO-MECHANICAL IMMOBILISATION  
ASSET MANAGEMENT & FREE K-ESAR REGISTRATION**

[WWW.KOSRAN.COM](http://WWW.KOSRAN.COM)

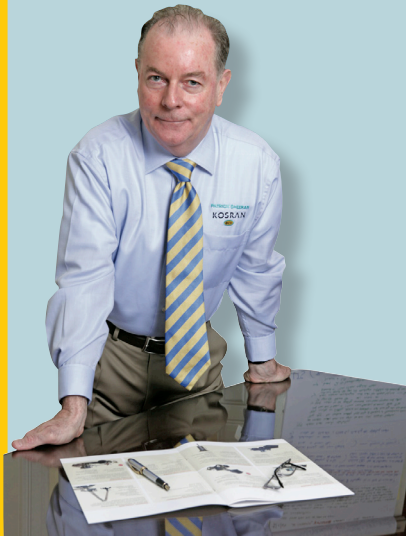

Mr Patrick Sheeran MRICS  
CEO - Kosran ECV limited

## SAFETY | SECURITY | CONTROL FOR ACCESS & CONSTRUCTION EQUIPMENT

### THE PERFECT PARTNER:

Kosran Engineering led By Professor Thomas Brazil in Dublin, Ireland is a proven innovator. We have a clear vision of the Contractors, Hire Company & OEM future needs and we offer to keep your business at the vanguard of innovation in this niche sector which demands constant investment and product development to provide our mutual customers with improved productivity and profits. This is our commitment. We have no competitor comparative or otherwise.

two engineering tasks (1) Electrical - we share with you the loom and connector specification changes you need to make to your existing looms to interface with Kosran and (2) Mechanical - we design the hardened steel security shields which are required to protect the electro-mechanical ECV-Electronic Coded Valve deterrent against tampering.

Kosran has already concluded similar programmes with Caterpillar (UK & USA), Takeuchi (Japan), Ammann Equipment & Volvo (France) with other advanced and ongoing programmes in place. We would welcome the opportunity to visit you and to demonstrate what we offer.

### WHAT IS YOUR PLAN TO PROVIDE SAFETY, SECURITY AND CONTROL?

What plans does your company have to contain your Contractor & Hire Company customers' current and future exposure to theft; to third party claims from unauthorised machine use; and their need to manage their assets in a more productive way to improve their bottom line? Is it universal key?

### ENGINEERING:

Kosran is factory fit on Caterpillar E Series BHL for EMEA. When this project concluded Kosran re-specified the build of our standard product to the Caterpillar product specification. Kosran is a CAT spec system.

The implementation of an 'OEM ACCESSORY PROJECT' involves

*"While plant continues to use mechanical diesel engines, electronic immobilisers (as found on cars) are ineffective and electro-mechanical immobilisation systems should be used. Electro-mechanical systems primarily shut-off the diesel fuel supply and/or the hydraulics"* **September 2007.**  
**P 27 UK Home Office Report.**

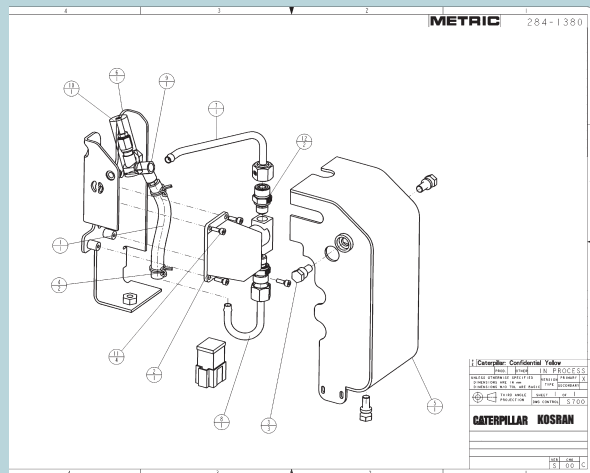
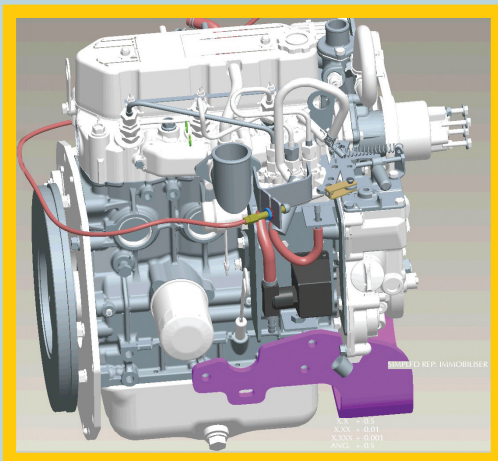



## SAFETY | SECURITY | CONTROL FOR ACCESS & CONSTRUCTION EQUIPMENT



Another global 1st from Kosran... New ECV Comms Keypad system that integrates machine telematics/asset management with its immobilisation system.



No Keys. It operates by Keypad PIN Code for fleets and by FoB for smaller operators. The flexible 22 PIN code facility allows every code to be changed or deleted.

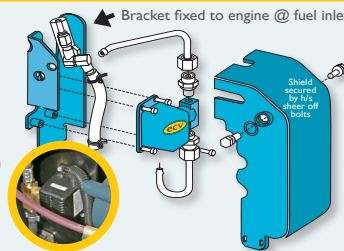

If it isn't electro-mechanical immobilisation it won't stop un-authorized use or stop your plant being stolen.



Thieves fail against Kosran electro-mechanical system again.

### FEATURES

- Our ECV® - Electronic Coded Valve® shuts-off the diesel fuel supply and locks the hydraulics.
- The deterrent sets automatically every time you switch the engine off.
- Control your fleet by remotely immobilising your plant via computer or mobile phone procedure at random or set times e.g. weekends.
- Our service alert facility knows the hours your machines have worked and you only service them and sell them based on hours worked and not the machines age.
- We track & locate - the nearest available machine to the next job, not the furthest.
- Your engineers and drivers have personal Keypad PIN codes to access or recover plant 24/7.
- You are an insurable risk with Kosran and avoid residual disputes.
- For the thief - Kosran is just too much hassle to bypass, requires too much equipment and expertise and takes too long to steal. It's easier to steal someone else's machine.

**The Kosran ECV Comms Keypad System will increase revenues, improve utilisation, reduce maintenance costs, gain operational efficiencies, decrease un-authorized use. Kosran is not a cost, it is a benefit.**

### WE STOP UN-AUTHORISED USE AND PLANT THEFT



**Kosran stops the unauthorised use of plant during work or downtime. We stop anyone without training, competence or authorisation; juvenile, thief or employee; from causing malicious, personal or 3rd Party damage.**

# KOSRAN

ecv

## THE PROFITABLE ACCESSORY FOR OEM MANUFACTURERS FOR THE PRICE OF A DEUSTCH CONNECTOR

KEEPING YOU AND YOUR CUSTOMERS AT THE VAN-GUARD OF  
**SAFETY SECURITY ASSET MANAGEMENT**



### ACCESS EQUIPMENT SAFETY

- Is your access equipment being moved when it should not be?
- By people who should not be operating it ?
- Is your access equipment doing week-end nixers?
- These people are a danger to themselves and could lose their head. But they are your responsibility.
- Are you meeting your responsibilities under the UK Corporate Manslaughter Act 2007?
- Access-Kosran can provide a complete solution including remote access control. When Kosran electro-mechanically shuts down a machine, it stays shut-down.



**NO unauthorised users**

**FREE K-ESAR REGISTRATION.** During installation we fix indestructible labels with a UPN-unique part number in remote inaccessible locations throughout the machine e.g. engine and cab department. We supply you with an Audit Installation Document in triplicate for insurers etc. This comprehensive document is a complete record of the machines identity. If your machine is stolen, which it won't be – and is recovered by the Police – we can identify that you are the legitimate owner of the machine. This is K-ESAR Registration and this service is free of charge to our customers.

# KOSRAN

ecv

## YOU ARE A GOOD INSURANCE RISK WITH KOSRAN SECURED PLANT

### INSURANCE TESTIMONIAL FROM EJK CONTRACTORS

Willen Road, Newport Pagnall MK16 0JJ

*“Credit where credit is due. Kosran’s brochure wasn’t just bull. It really did save me £300 PER MACHINE on my insurance. I lost a machine before fitting Kosran and now I know that my machines are safe and secure for very little outlay.”* **Eddie Kidd.**

### THE BEST EVER PLANT THEFT POLICY



- **Zero Claims Excess** – nil policy excess for theft claims.
- Up to **35% premium discount.**
- **The hire of an equivalent alternative machine for 28 days.**
- **New for old**, no quibble, for loss or damage to plant under 12 months old.
- Loss or damage to plant 2-5 years old quickly settled on **agreed depreciation basis of 10% p.a.** for replacement machine purchase.
- This is the **best ever plant theft policy** offered to the industry and is exclusive to Kosran who has achieved it on our record in the field.
- Visit [www.kosran-plantinsurance.com](http://www.kosran-plantinsurance.com) Tel: 0870 787 5 621



Norwich Union encourages positive risk management and recognises the value and effectiveness of the Kosran product as the only electro-mechanical immobiliser which meets the Thatcham industry standard. Accordingly we offer a range of insurance benefits to the owner or hirer of Kosran protected plant. Cover is underwritten by Norwich Union.

Kosran-plantinsurance is a trading name of Bridle Insurance Brokers Limited who are authorised and regulated by the Financial Services Authority.

### THE £1,000 KOSRAN GUARANTEE FOR HIRED-IN PLANT

If you hire-in Kosran secured machines and a machine is stolen, provided it is not ‘an inside depot job’ and is insured under the Kosran Norwich Union Policy, then following their settlement of your claim, Kosran will give you a cheque for £1,000 towards your downtime losses for every Kosran secured machine stolen. Terms & Conditions apply – *but no sneaky stuff.*

### INSURERS LIKE TO INSURE A SECURED RISK

# KOSRAN

ecv

## THE BLAGGERS GUIDE TO PLANT SECURITY

- 1** Trackers real name: Asset Management. Should kick-in after it's stolen, you have a <5% chance of it being recovered AND it will cost you.
- 2** Electronic immobilisers on plant cut the electrical circuits. Without exception they can be hot-wired in maximum 90 seconds (*no matter who they are certified by*). They make your plant more vulnerable to theft because the operator is less vigilant parking up because he thinks the machine is secured – which it isn't.
- 3** Trackers with Electronic Immobiliser ... see 1 & 2 above – won't stop it being stolen and you won't get it back.
- 4** Kosran stops plant theft & unauthorised use; we stop fatalities and make safety a priority. We have integrated machine telematics/asset management with our electro-mechanical immobilisation system. No Kosran system has ever been bypassed.

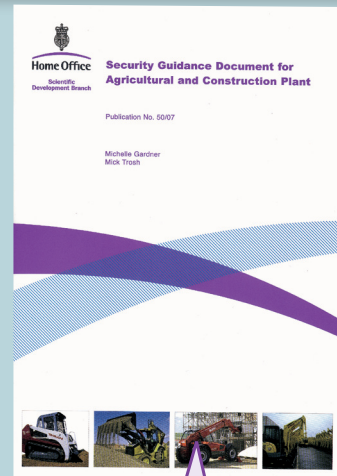

"While plant continues to use mechanical diesel engines, electronic immobilisers (as found on cars) are ineffective and electro-mechanical immobilisation systems should be used. Electro-mechanical systems primarily shut-off the diesel fuel supply and/or the hydraulics" **September 2007. P 27 UK Home Office Report.**

Kosran is an engineering company and endorses the above Home Office specification. In the UK we are the industry standard and endorsed by the Top 5 Plant insurers on performance and merit. We have never had a machine bypassed and stolen. Our Kosran 'fit for purpose' Standard demands safe and secure systems which will resist bypass and attack for a minimum of 30 minutes.

### What the thief already knows and his tool-kit:

Take 3 or 4 way crocodile clips, connect to battery power, ESOS shut-off solenoid (maybe also electric pump) then touch live off starter motor and machine will start up independently of the immobiliser.

Only electro-mechanical immobilisation stops un-authorized use and your plant being stolen.



◀ This complete tool-kit is used throughout the world by plant thieves to hot wire and bypass in under 90 seconds, every electric circuit cutting electronic immobiliser installed on construction machines including Kubota, JCB & Manitou.

- 1** Wire Strippers
- 2** Test probe
- 3** Side Cutters
- 4** 4 Way Crocodile Clip

Kosran ECV (Europe) Limited.

**T [UK]:** +44 (0) 87078 75687

**E [UK]:** sales@kosran.com

**T [FR]:** +33 (0) 820 20 21 65

**E [FR]:** ventes@kosran.com

**T [IRL]:** +353 1 677 8258

**E [IRL]:** info@kosran.com